

Speed Control of Non-located Stator-Rotor Synchronous Motor with Application in Robotic Surgery

Alireza Mohammadi*, Danielius Samsonas*, Christian Di Natali[†], Pietro Valdastrì[†], Ying Tan*, Denny Oetomo*

*Melbourne School of Engineering, The University of Melbourne, Melbourne, Australia

[†]Department of Mechanical Engineering, Vanderbilt University, Nashville, TN, USA

Email: alirezam@unimelb.edu.au and christian.di.natali@vanderbilt.edu

Abstract—This paper introduces Non-located Stator-Rotor Synchronous Motor (NSRSM) as a novel actuation system for cases where the stator and rotor are required to interact across a physical barrier. The main motivation for NSRSM is in the area of laparoscopic robotic surgery whereby it is desired to actuate the manipulators across the abdominal wall, but it also has potential application in other robotic surgery procedures. The configuration of NSRSM is similar to that of permanent magnet synchronous motor (PMSM) although due to asymmetric structure of the windings around the rotor, the electromechanical model of PMSMs was developed to obtain the dynamic model of NSRSM. The *field oriented control* method is used to develop an appropriate model for control purposes. Then two widely used control algorithms (PI controller and linear quadratic regulator (LQR)) are used to control the rotor speed in the presence of the modelling uncertainties and load disturbances. Simulation results show that these two methods are robust.

Keywords—*Permanent magnet synchronous motor, robotic surgery, field oriented control, LQR.*

I. INTRODUCTION

In the last decade, surgical advances have focused on techniques to minimise the invasiveness of operations in order to reduce the resulting trauma; such as advances in laparoscopic techniques [7]. Current promising approaches are developed in robotic surgery for reducing access trauma using laparoscopic single site surgery [1]. In these cases, the robotic manipulators are actuated through on-board motors. However, the performance of the motors that can fit through the small (20mm) incision is limited.

In one of the most recent studies [9], the authors proposed a novel approach called Local Magnetic Actuation (LMA) to transfer mechanical power across the abdominal wall by a magnetic coupling which eliminates the need for embedded actuators and wired connections. The LMA is composed of an anchoring unit to support the instrument during the surgery and an actuation unit to transfer power to internal driven magnet via rotating external driving magnet. The technique has the advantage of requiring only one incision through which the (internal) surgical units can be inserted and then actuated from outside the abdominal wall. Additionally, stator components of the actuations can be placed outside the abdominal cavity, thus allowing space saving within the cavity and the use of larger external actuation components capable of delivering higher performance.

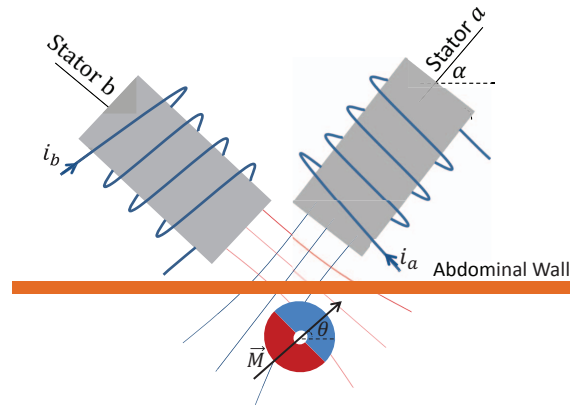

Fig. 1. Schematic of Non-located rotor and stator

The magnetic field linkage is inversely proportional to the thickness of the abdominal wall separating the external magnets and the internal magnets in the LMA technique [9]. Therefore, in a larger distance, the provided torque will be small. In addition, increasing the load torque can cause *pole slipping* between external and internal driving magnets and consequently reducing the amount of transferred torque significantly. Misalignment of rotational axis of two permanent magnets is also another issue with LMA. The LMA system in [9] consists of permanent magnets, therefore is unable to compensate for these variations in physical parameters conveniently.

In this paper, it is suggested to replace the external permanent magnet in LMA by electromagnets to provide more control variables to enable better performance. As shown in Fig. 1, the magnetic field is produced by a pair of electromagnetic coils and is transferred across abdominal wall and interacts with the magnetic field of the permanent magnet rotor. The magnitude of the magnetic fields can be regulated by changing the magnitude of current in the coils. As a result, in the case of large stator-rotor distance or high load torque, the magnitude of currents in the coils can be increased to compensate for the reduction of torque in permanent magnet inside the abdominal wall. Additionally, the ability to vary the actuation command to the electromagnetic coils would allow the software compensation of mechanical uncertainties and inaccuracies, such as variable thickness and the misalignment of rotational axis suffered by the LMA.

The structure of the proposed actuation system in Fig. 1 is similar to that of Permanent Magnet Synchronous Motor (PMSM) although there is a significant difference. In PMSMs, the stator coils surround the entire circumference of the permanent magnet rotor in a circular and symmetric manner while in the proposed system, stator coils can only be located on one side of the rotor, which is the side facing the abdominal wall. For this reason, the proposed system is tentatively labelled Non-collocated Stator-Rotor Synchronous Motor (NSRSM).

Since it is not possible, or at least inconvenient, to place more stator coils on the other side of the rotor in the NSRSM design, there is no physical symmetry in its structure. Having no symmetry causes more severe torque ripple compared to conventional motors. In addition, due to the variation in distance between stator and rotor of NSRSM, the parameters of the model is time-varying. Due to these differences, the model of PMSMs and their control schemes cannot be directly used for NSRSM.

Therefore, the first purpose of this paper is to develop the electromechanical model of NSRSM using the model of PMSMs. This model should be simple for control purposes while it captures all the important dynamic characteristics of NSRSM. The second objective of this study is to propose appropriate control schemes to generate a smooth torque with taking into account the asymmetric structure of NSRSM.

In PMSMs, since the back-emf voltage is sinusoidal, the controller should attempt to provide sinusoidal current signals with an appropriate relative phases such that permanent magnet rotate smoothly. The conventional control method is to feed desired sinusoidal current signals to a pair of PI controllers to regulate current signal in each coil. This will result in a smooth rotation provided that the output current waveform accurately track the desired sinusoidal signal. However, the main problem with this method is that the controller attempts to track a time-varying signal which in general is difficult in high speeds [6]. The *field oriented control* can solve this problem by controlling the current signals in a new coordinate system rotating with rotor speed [5]. In this coordinate, the current signals are constant and independent of rotor position. Consequently, performance of the controllers are generally independent of the speed of the rotor. Then, well-established control methods can be employed for current control in the coils.

Although the back-emf voltage in NSRSM is sinusoidal similar to PMSMs, the PMSM control schemes cannot be directly applied to NSRSM due to its asymmetric structure and variable model parameters as mentioned above. Therefore, an appropriate control schemes should be proposed to generate a smooth torque and these controllers should be robust enough to track a desired speed in the presence of load disturbance and model uncertainties.

II. DYNAMIC MODEL OF NSRSM

The schematic diagram of the proposed NSRSM is depicted in Fig. 1. NSRSM has at least two stator windings labelled as stator a and stator b and a permanent magnet as rotor. Two electromagnetic coils were used to produce a unique motion (speed and direction of rotation) of the rotor, located across the

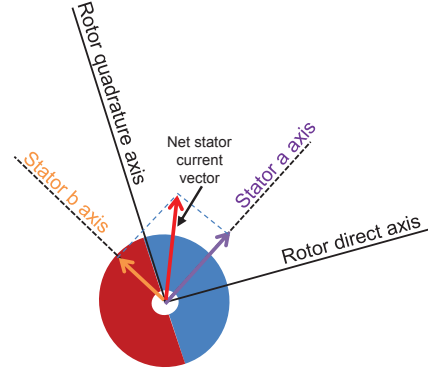

Fig. 2. The schematic of the net stator current vector based on current vectors of stator a and stator b

abdominal wall. The electrical equations of NSRSM is similar to PMSM and can be represented as [10]:

$$v_a = R_s i_a + L_a \frac{di_a}{dt} + e_a, \quad (1)$$

$$v_b = R_s i_b + L_b \frac{di_b}{dt} + e_b, \quad (2)$$

where v_a and v_b are the stator phase voltages, R_s is the stator resistance per phase, i_a and i_b are the stator phase currents, L_a and L_b are the self-inductance of phases a and b and e_a and e_b are the phase back electromotive forces (back-emfs) which are as follows:

$$e_a = \omega \lambda_m \sin(\theta), \quad (3)$$

$$e_b = \omega \lambda_m \sin(\theta - \frac{\pi}{2}). \quad (4)$$

where ω is the angular speed of the rotor, λ_m is the flux linkage of the permanent magnet and θ is the rotor position.

The dynamic motion of the permanent magnet rotor can be represented as:

$$J \frac{d\omega}{dt} + b\omega = T_e - T_l - T_{cog} \quad (5)$$

where J is the total moment of inertia, b is the friction coefficient, T_e is the electromagnetic torque, T_l is the load torque and T_{cog} is the cogging torque.

In this paper the following assumptions are considered for NSRSM:

- The resistance and inductance of two coils are equal ($L_a = L_b = L$),
- The mutual inductance is small,
- The cogging torque is negligible ($T_{cog} = 0$).

The electromagnetic torque, T_e , is the consequence of the interaction between of the permanent magnet field, \vec{M} , and the stator magnetic field, \vec{B} , which can be represented as:

$$T_e = \vec{M} \times \vec{B}. \quad (6)$$

Therefore, if the stator magnetic field is orthogonal to the field of the rotor, the produced torque is maximum. On

the other hand, if two fields are parallel to each other, no torque is produced. Since the magnetic fields of the coils are proportional to the current, it is more convenient to use coil currents instead of magnetic field of the coils. As a result, the net stator current can be considered as a vector which is aligned at the direction of the net stator field as shown in Fig. 2. The purpose of NSRSM control is that, in each position of rotor, produce current signals in coils such that the current vector is orthogonal to the permanent magnet rotor axis. The stator current can be divided to two orthogonal components in parallel and perpendicular to the axis of the rotor labeled as quadrature and direct. Therefore, the control goal will be simplified to producing current signals such that the current in direct direction is zero. Consequently, the produced torque is proportional to the current in the quadrature direction.

Similar to PMSMs, the electromagnetic torque, T_e , in terms of current, back-emf and rotor speed can be expressed as [10]:

$$T_e = (e_a i_a + e_b i_b) / \omega. \quad (7)$$

Then, substituting (3)-(4) in the above equation gives:

$$T_e = \lambda_m (\sin(\theta) i_a + \sin(\theta - \frac{\pi}{2}) i_b). \quad (8)$$

This equation also shows that the torque is a function of rotor position, θ , and in each position of rotor, there are optimal values of the current vectors i_a and i_b that provides maximum torque. Therefore, in order to produce maximum torque, the current signal should be generated as:

$$i_a = I_s \sin(\omega t) \quad (9)$$

$$i_b = I_s \sin(\omega t - \frac{\pi}{2}) \quad (10)$$

where I_s is the stator current. Substituting the above equations in the torque equation (7) results in:

$$T_e = \lambda_m I_s (\sin^2(\omega t) + \sin^2(\omega t - \frac{\pi}{2})) = \lambda_m I_s. \quad (11)$$

PMSMs have at least N stator coils surrounding the rotor, $N \geq 3$, where the stator coils are arranged evenly $360/N$ degrees apart from each other. Therefore, current signals are phase shifted $360/N$ degrees while in NSRSM the coils should be oriented on axes with 90 degrees angle between them (see Fig. 1) and then current signals should be phase shifted 90 degrees from the other one.

Equation (11) shows that in order to produce constant smooth torque without rippling, the current signals (9), (10) should be constant in magnitude and frequency, irrespective of rotor position. This requires very accurate measurement of currents and rotor position and in cases that desired torque changes, tracking of time-varying current signal is required. This is achievable in low speeds, however, as motor speed increases, the controller should track a sinusoidal current signal with increasing frequency. Also, the controller should overcome the variation in amplitude and frequency of back-emf as speed changes. Field-oriented control can address this problem by controlling current signals in the rotating d-q frame which is explained in the next section.

III. FIELD-ORIENTED CONTROL

Since electrical equations represented above are dependent on position of permanent magnet flux, it is not easy to design a speed or torque controller with well-established control methods. The main goal of field-oriented control (FOC) is to decouple torque (quadrature) and magnetising flux (direct) components of the stator magnetic field, as shown in Fig. 2, and therefore remove the dependency to rotor position by projecting the system equations in d - q system that rotates at the speed of the rotor. This projection is known as Park transformation which is given by [6]:

$$i_q = -\sin(\theta) i_a + \cos(\theta) i_b, \quad (12)$$

$$i_d = \cos(\theta) i_a + \sin(\theta) i_b. \quad (13)$$

In this new coordinate system, the electrical equations are represented as:

$$v_q = R_s i_q + L_q \frac{di_q}{dt} + \omega \lambda_d, \quad (14)$$

$$v_d = R_s i_d + L_d \frac{di_d}{dt} - \omega \lambda_q, \quad (15)$$

where

$$\lambda_q = L_q i_q, \quad (16)$$

$$\lambda_d = L_d i_d + \lambda_m, \quad (17)$$

v_d and v_q are the d, q axis voltages, i_d and i_q are the d, q axis stator currents, L_d and L_q are the d, q axis inductances and λ_m is the flux linkage due to the rotor magnets linking the stator.

Also, the electromagnetic torque in this new reference frame is:

$$T_e = \lambda_d i_q - \lambda_q i_d. \quad (18)$$

Based on equation (18), in order to produce maximum torque for a given stator current, the current in d -axis should be set to zero.

Considering equations (14), (15) and (18), system dynamics can be expressed in state-space form as:

$$\frac{di_q}{dt} = (v_q - R_s i_q - \omega - L_d \omega i_d - \lambda_m \omega) / L_q, \quad (19)$$

$$\frac{di_d}{dt} = (v_d - R_s i_d + L_q \omega i_q) / L_d, \quad (20)$$

$$\frac{d\omega}{dt} = (T_e - T_l - b\omega) / J. \quad (21)$$

In order to find the currents and voltages in a-b coordinate, the following inverse Park transformation can be applied:

$$\begin{Bmatrix} S_a \\ S_b \end{Bmatrix} = \begin{bmatrix} -\sin(\theta) & \cos(\theta) \\ \cos(\theta) & \sin(\theta) \end{bmatrix} \begin{Bmatrix} S_q \\ S_d \end{Bmatrix},$$

where S is replaced by voltage, v , or current, i .

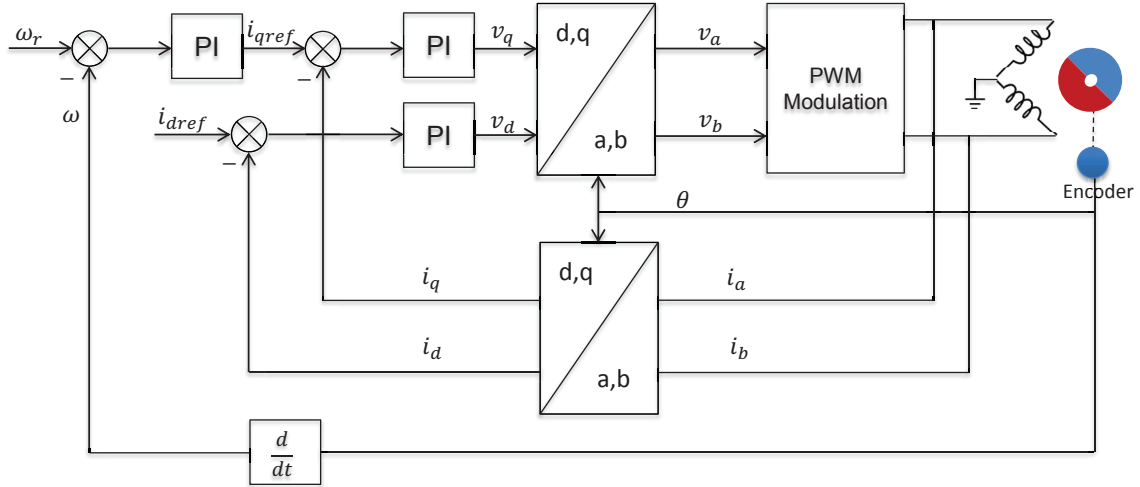

Fig. 3. The basic scheme of FOC with PI-based controller

IV. PI-BASED CONTROLLER DESIGN

As mentioned in the previous section, after expressing the electromechanical equations in d - q reference frame, the control goal is to control voltage signals v_q and v_d such that the current i_d is zero for a desired speed and torque command. Fig. 3 shows the basic schematic of implementation of PI-based FOC for NSRSM. The required measurements for this control are currents of two coils and rotor position. The measured currents, i_a and i_b , are feed to the Park transformation and its output, i_q and i_d are compared to i_{qref} and i_{dref} and fed back to the PI controllers. The i_{qref} signal is produced by the required torque demanded by the speed regulator and i_{dref} should be set to zero as explained in the previous section. The outputs of the current controller, v_q and v_d are fed into the inverse Park transformation and then applied to the coils as v_a and v_b . It should be noted that both Park and inverse Park transformation require the rotor position which can be provided by a Hall effect sensor. The derivative of the position signal is also used as rotor speed feedback signal.

This control scheme consists of two control loops: the inner control loop that regulates current signals and the outer velocity control loop that attains the desired velocity. Both of these controllers are based on conventional proportional-integral (PI) with velocity and currents as feedback. Therefore, the control laws for the current signals and the rotor velocity are:

$$v_q = K_{pq}\tilde{i}_q + K_{iq} \int \tilde{i}_q dt, \quad (22)$$

$$v_d = K_{pd}\tilde{i}_d + K_{id} \int \tilde{i}_d dt, \quad (23)$$

$$i_{qref} = K_{p\omega}\tilde{\omega} + K_{i\omega} \int \tilde{\omega} dt, \quad (24)$$

where $\tilde{i}_q = i_q - i_{qref}$, $\tilde{i}_d = i_d - i_{dref}$, $\tilde{\omega} = \omega - \omega_{ref}$ and (K_{pq}, K_{iq}) , (K_{pd}, K_{id}) and $(K_{p\omega}, K_{i\omega})$ are proportional and integral gains of quadrature current, direct current and rotor speed, respectively.

V. LQR-BASED CONTROLLER DESIGN

PI controllers are widely applied in control of industrial systems due to their simple structure and good performance without requiring *a priori* knowledge about the plant model. However, it is difficult to tune the controller gains and there is no guarantee regarding performance and stability of the system.

Linear-Quadratic Regulator (LQR) can address the aforementioned problems. The goal of LQR is to find gains of the feedback control such that the given cost function is minimised. As a result, it achieves a compromise between the control effort and tracking performance that will guarantee stable performance of the system. In this method, the inner and outer layers of the control will be replaced by one controller that regulates the rotor speed, ω , and current signal in direct axis, i_d .

The design procedure in LQR requires a linear model of the system. Therefore, the nonlinear system (20)-(21) is linearised around its equilibrium point at $i_q = i_d = \omega = 0$ which gives:

$$\dot{x} = Ax + Bv, \quad (25)$$

$$y = Cx, \quad (26)$$

where $x = [i_q \ i_d \ \omega]^T$, $v = [v_q \ v_d]^T$ and

$$A = \begin{bmatrix} -\frac{R_s}{L_q} & 0 & -\frac{\lambda_m}{L_q} \\ 0 & -\frac{R_s}{L_d} & 0 \\ \frac{\lambda_m}{J} & 0 & -\frac{b}{J} \end{bmatrix},$$

$$B = \begin{bmatrix} \frac{1}{L_q} & 0 \\ 0 & \frac{1}{L_d} \\ 0 & 0 \end{bmatrix}, \quad C = \begin{bmatrix} 0 & 1 & 0 \\ 0 & 0 & 1 \end{bmatrix}$$

Since we want to design a controller that regulates the rotor velocity to the desired velocity, ω_{ref} , and the direct current, i_d , to zero, the error system is constructed as:

$$\dot{\tilde{x}} = A\tilde{x} + Bu, \quad (27)$$

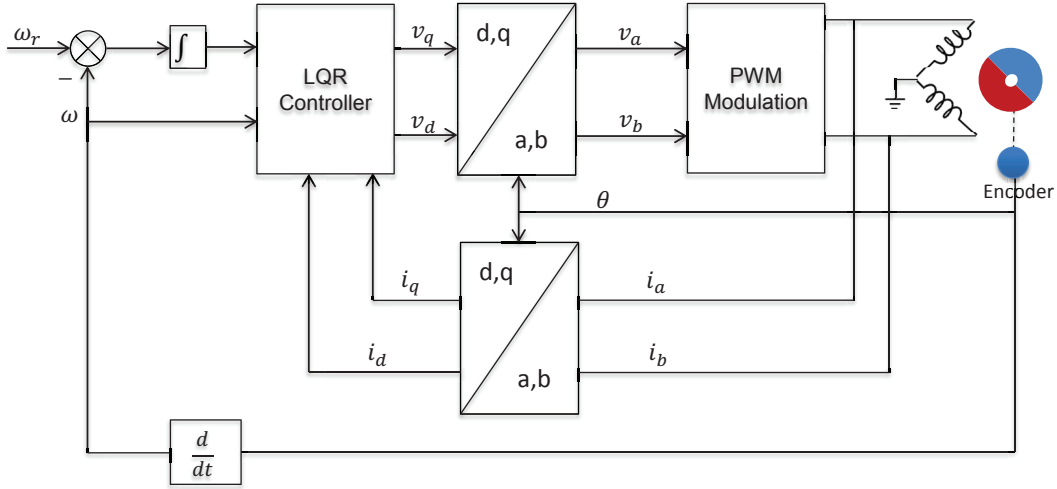

Fig. 4. The scheme of FOC with LQR-based controller

where $\tilde{x} = [\tilde{i}_q \ \tilde{i}_d \ \tilde{\omega}]^T$, $u = [V_q \ V_d]$, $\tilde{i}_q = i_q - \frac{b\omega_r}{\lambda_m}$, $\tilde{i}_d = i_d$, $\tilde{\omega} = \omega - \omega_r$, $V_q = v_q - (\frac{b\omega_r}{\lambda_m} + \omega_r \lambda_m)$ and $V_d = v_d - \frac{-L_q b \omega_r^2}{\lambda_m}$.

The cost function is considered as:

$$J(x) = \int_0^\infty (\tilde{x}^T Q \tilde{x} + u^T R u) dt \quad (28)$$

where $Q = Q^T \geq 0$ and $R = R^T > 0$. Then, the feedback control law that minimises the cost is

$$v = -K_1 \tilde{x}, \quad K_1 = R^{-1} B^T P, \quad (29)$$

and P is found by solving the algebraic Riccati equation

$$A^T P + P A - P B R^{-1} B^T P + Q = 0. \quad (30)$$

The LQR controller can achieve the desired performance and trajectory tracking provided that a perfect model of the system is available. However, in NSRSM, due to variation in distance between the coils and the permanent magnet rotor there are uncertainties in the system model. In addition, there is load disturbances which should be rejected appropriately. A potential solution instead of retuning the feedback gains is to make use of integral action as explained in the next section.

A. Internal Model Principle

In systems that exogenous signals such as desired trajectory and input disturbances are generated by a known model, asymptotic output tracking in the presence of input disturbance can be achieved by including such model in the feedback controller. This method is known as internal model principle (IMP) [3]. In the cases that the exogenous signals are constant, asymptotic regulation of output to the desired trajectory and disturbance rejection can be achieved by including integral action in the control.

In order to introduce the integral action, the regulation error, $e = y - r$ where $r = [i_d \ \omega]$, is integrated and therefore the augmented model is obtained as:

$$\dot{\tilde{x}} = A \tilde{x} + B u, \quad (31)$$

$$\dot{\sigma} = e. \quad (32)$$

Given the augmented system, the feedback control law is of the form

$$u = -K_1 \tilde{x} + K_2 \sigma \quad (33)$$

where K_1 is the LQR state feedback term and K_2 is the integral term.

This controller guarantees asymptotically stable equilibrium point of the augmented system. As a result, although parameter uncertainties of the model will change the equilibrium point, the condition $e = 0$ warrants the trajectory tracking in the presence of parameter uncertainties of the model. The schematic of this controller scheme is shown in Fig. 4.

VI. SIMULATION RESULTS

In this section, the proposed control schemes are tested through simulations. The NSRSM is required to track a desired speed, $\omega_r = 20 \text{ rad/s}$. For the simulation purposes, the parameters of the NSRSM model are considered as Table. I similar to [8].

TABLE I. MODEL PARAMETERS OF NSRSM

Resistance (R_s)	0.8 Ω
Inductance (L)	60 mH
Friction Coefficient (b)	0.0000828 Nms
Total Moment of Inertia (J)	$0.56 \times 10^{-6} \text{ kgm}^2$
Flux Linkage of Permanent Magnet (λ_m)	0.007 V/rad/s

In order to investigate the robustness of the designed controllers in the presence of load disturbances, a disturbance torque $T_l = 3 \text{ mNm}$ is applied at $t = 1 \text{ sec}$. In addition, as mentioned in Introduction, depending of the thickness of abdomen wall, the distance between stator and rotor is variable. This variation has a direct influence on back-emf voltage and electromagnetic torque due to variation in flux linkage of permanent magnet, λ_m . Therefore, the performance of the control schemes are also assessed in terms of model uncertainties by varying value of λ_m from 0.007 to 0.005 at $t = 2 \text{ sec}$.

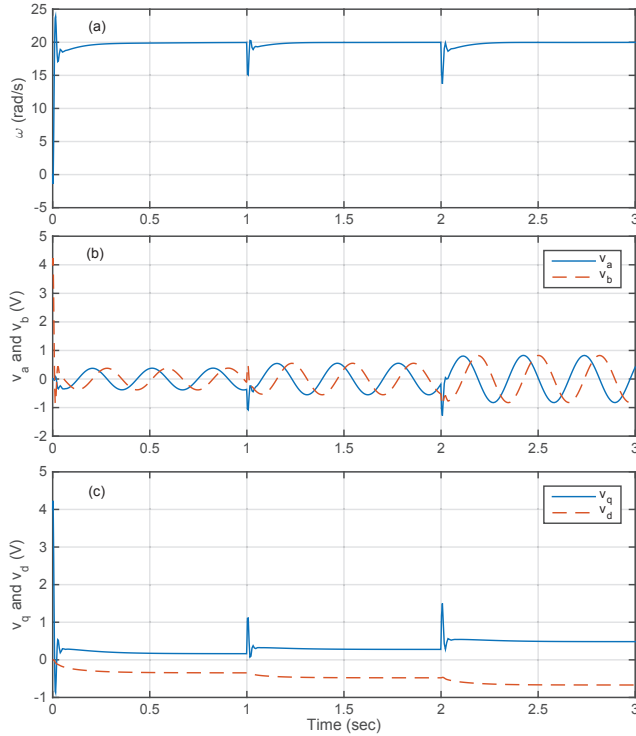

Fig. 5. Simulation results of implementation PI controller for speed regulation of NSRSM with torque disturbance at $t = 1\text{sec}$ and parameter variation (λ_m) at $t = 2\text{sec}$; (a) Rotor speed, (b) Voltage control inputs to stator a and stator b, (c) Control voltages in d - q coordination

Based on the parameters of the model in Table I, the gains of PI controller are tuned for the best performance of the controller. The gains of PI controller are obtained as ($K_{pq} = 0.2, K_{iq} = 1$), ($K_{pd} = 1, K_{id} = 10$) and ($K_{p\omega} = 1, K_{i\omega} = 10$) for quadrature current, direct current and rotor speed, respectively. As it was expected, the inner loop which includes quadrature and direct current control is faster than the outer speed control. In future, a better and systematic tuning method such as extremum seeking based PI controllers will be explored [4].

The state feedback and integral gains of the LQR-IMP controller are also obtained as:

$$K_1 = \begin{pmatrix} 10.28 & 0 & 0.087 \\ 0 & 0.03 & 0 \end{pmatrix}, \quad K_2 = \begin{pmatrix} 20 & 0 \\ 0 & 7 \end{pmatrix}$$

The simulation results are shown in Fig. 5 and Fig. 6. The results show that both PI controllers and LQR controllers work well in the presence of disturbances and uncertainties. These results demonstrate the effectiveness of design procedures. Fine tuning methods will be used in experiments in near future.

VII. CONCLUSIONS

Non-collocated stator-rotor synchronous motor as a novel actuation system in robotic surgery has been introduced in this paper. The dynamic model of this system and two control schemes, PI and LQR-IMP, have been presented. The simulation results show that both of controllers can track the desired angular velocity of rotor and handle the load disturbances and uncertainties in the model parameters.

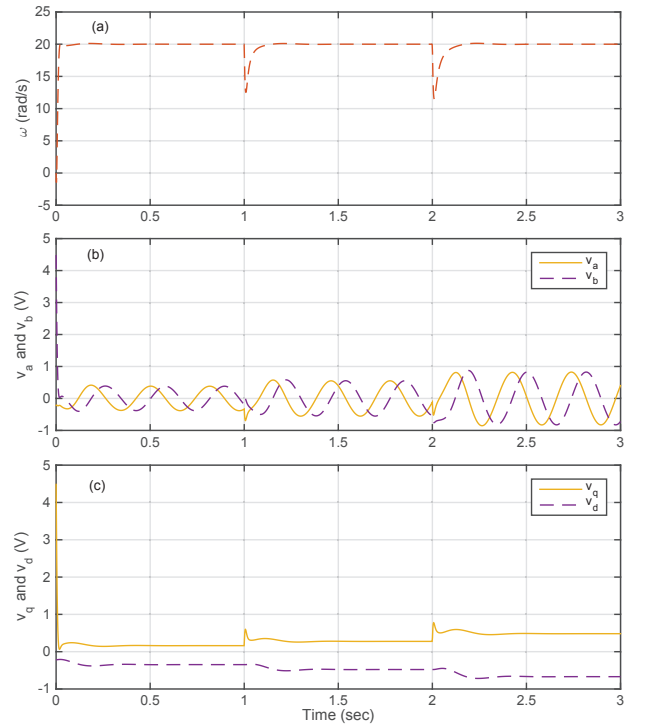

Fig. 6. Simulation results of implementation LQR-IMP controller for speed regulation of NSRSM with torque disturbance at $t = 1\text{sec}$ and parameter variation (λ_m) at $t = 2\text{sec}$; (a) Rotor speed, (b) Voltage control inputs to stator a and stator b, (c) Control voltages in d - q coordination

REFERENCES

- [1] Fader, A. N. and Escobar, P. F., "Laparoscopic single-site surgery (LESS) in gynecologic oncology: technique and initial report", *Gynecologic Oncology*, vol. 114, no. 2, pp. 157-161, 2009.
- [2] Garbin, N., Di Natali, C., Buzzi, J., De Momi, E. and Valdastrì, P., "Laparoscopic Tissue Retractor Based on Local Magnetic Actuation", *Journal of Medical Devices*, vol. 9, no. 1, 011005, 2015.
- [3] Khalil, H., *Nonlinear Systems*, 3rd ed, Upper Saddle River: Prentice hall, 2002.
- [4] Killingsworth, N. J. and Krstic, M., "PID tuning using extremum seeking: online, model-free performance optimization", *IEEE Transactions on Control Systems*, vol. 26, no. 1, pp. 70-79, 2006.
- [5] Kubota, K., and Matsuse, K., "Speed sensorless field-oriented control of induction motor with rotor resistance adaptation", *IEEE Transactions on Industry Applications*, vol. 30, no. 5, pp.1219-1224, 1994.
- [6] Low, T. S., Lee, T. H., Tseng, K. J. and Lock, K. S., "Servo Performance of a BLDC Drive with Instantaneous Torque Control", *IEEE Transactions on Industry Applications*, vol. 28, no. 2, pp. 455-462, 1992.
- [7] Mack, M. J., "Minimally invasive and robotic surgery", *Journal of the American Medical Association*, vol. 285, no. 5, pp. 568-572, 2001.
- [8] Mohammadi, A., Di Natali, C., Samsonas, D., Valdastrì P., Tan, Y. and Oetomo, D., "Electromagnetic Actuator across Abdominal Wall for Minimally Invasive Robotic Surgery", *Accepted in ASME Journal of Medical Devices*, 2014.
- [9] Natali, C. Di, Ranzani, T., Simi, M., Menciassi, A., and Valdastrì, P., "Trans-abdominal active magnetic linkage for robotic surgery: Concept definition and model assessment", in *Proceedings of IEEE International Conference on Robotics and Automation*, pp. 695-700, 2012.
- [10] Pillay, P. and Krishnan, R., "Modeling, simulation, and analysis of permanent-magnet motor drives. I. The permanent-magnet synchronous motor drive", *IEEE Transactions on Industry Applications*, vol. 25, no. 2, pp. 265-273, 1989.